

# Integrated safety device Comem RIS2

## Instruction manual



### Content

<b>1. Safety</b>	2
1.1 Safety instructions	2
1.2 Specified applications	2
1.3 Safety notes on the equipment operation	2
<b>2. Comem RIS2</b>	3
2.1 Introduction	3
2.2 Description and functions	3
2.3 Drawings	4
2.4 General feature	4
2.5 Current	5
2.6 Wiring diagram	5
<b>3. Installation</b>	6
3.1 Mounting instruction	6
3.2 Installations and operating instructions	8
3.3 Instructions for topping up the level on Comem RIS2	8
3.4 Drawings	10
<b>4. Test</b>	11

# 1. Safety

## 1.1 Safety instructions

Make sure that any persons installing, taking into operation and operating the safety detector:

- Are technically qualified and competent
- Fully comply with these assembling instructions

Improper operations or misuse could cause danger to:

- life and limb
- to the equipment and other assets of the operator
- to the equipment proper function

**Opening of the device will void your warranty.**

Safety instructions in this manual are shown in three different forms to emphasize important information.



WARNING

THIS INFORMATION INDICATES PARTICULAR DANGER TO LIFE AND HEALTH. DISREGARDING SUCH A WARNING CAN LEAD TO SERIOUS OR FATAL INJURY .



CAUTION

THIS INFORMATION INDICATES PARTICULAR DANGER TO EQUIPMENT OR OTHER PROPERTY OF THE USER. SERIOUS OR FATAL INJURY CANNOT BE EXCLUDED.



NOTE

THIS NOTES GIVE IMPORTANT OR SPECIFIC INFORMATION CONCERNING THE EQUIPMENT OR AS TO WORK WITH THE EQUIPMENT.

## 1.2 Specified applications

The RIS2 integrated safety detector is composed by a rugged plastic body, watertight and resistant to extreme climates, with houses a series of instruments and keeps constant control of the following operating conditions of the transformer:

- **Pressure**
  - Pressure switch: closes/opens a circuit on pressure ranging (from 100 up to 500 mbar)

- **Temperature**

- Thermometer: visual indication of oil temperature and max. temperature reached
- "T2" Thermostat switch: (alarm) closes/opens a circuit at a predetermined temperature level (from 30°C up to 120°C)
- "T1" Thermostat switch: (stop) closes/opens a circuit at a predetermined temperature level (from 30°C up to 120°C)

- **Oil level**

- Indicator: visual indicator of slight oil level variation
- Detector: visual detector of significant oil level variation through closing/opening of an electric circuit

- **Gassing**

- Detector: closes/opens a circuit when the max. gas volume is reached (max. 170 cm<sup>3</sup>)

It is important to observe the limit values indicated on the nameplate and in the operating instruction before commissioning the device.

## 1.3 Safety notes on the equipment operation

Electrical installation is subject to the relevant national safety rules.

It is mandatory to connect the grounding cable because of safety reason.



CAUTION

INSTALLATION, ELECTRICAL CONNECTION AND FITTING THE DEVICE MAY ONLY BE CARRIED OUT BY QUALIFIED PERSONNEL AND ONLY IN ACCORDANCE TO THIS INSTRUCTION MANUAL. IT IS RESPONSIBILITY OF THE USER TO MAKE SURE THAT THE DEVICE IS USED FOR SPECIFIED APPLICATION ONLY. FOR SAFETY MATTERS, PLEASE AVOID ANY UNAUTHORIZED AND IMPROPERLY WORKS.



WARNING

ALL RELEVANT FIRE PROTECTION REGULATION MUST BE STRICTLY OBSERVED.

## 2. Comem RIS2

### 2.1 Introduction

**Different functions efficiently combined in a single compact design**

Integrated safety detector Comem RIS2 was conceived from the need to integrate the functions performed by a number of transformer accessories

in a single, compact and reliable instrument, which was capable of replacing their applications, as well as guaranteeing numerous advantages ranging from an economic to functional-aesthetic viewpoint.

**Integrated safety detector according to EN 50216-3**



### 2.2 Description and functions

Description and functions	Measure	Checking test value
<p><b>Oil level (Float)</b>                      The device indicates any gas evolution or oil level variation.                      - Slight oil level variation or any insignificant gas evolution is denoted by the float position between "MIN" &amp; "MAX" on the display.                      - At major oil variation level or gas evolution the float stops at "MIN" and opens/closes the alarm circuit.                      - Any accumulated gas can be drawn off by the valve provided.</p>	Max 150 cm <sup>3</sup>	Locate the magnet close to the float (between MAX and MIN). Drawn it downwards until it reaches "MIN". To reset the float to its correct position draw the magnet upwards and detach.
<p><b>Pressure (Pressure switch)</b>                      This feature measures the internal pressure of transformer. The normal level is to be set by the user according to the transformer manufacturer's instructions. When pressure exceeds a pre set level the alarm circuit is triggered by a change over contact.</p>	100 mbar to 500 mbar	With the internal pressure at least 100 mbar set the adjusting knob of the pressure switch to minimum.
<p><b>Temperature</b>                      "T2" Thermostat switch (Alarm)                      The feature measures the internal oil temperature of the transformer. The normal operating value is to be set by the user according to the transformer manufacturers instructions. At a pre set temperature the alarm circuit is triggered by a change over contact (T2).</p>	30 °C to 120 °C	Open the rear cover using both hands, do not lever at one side only. The adjustment knob of the alarm switch "T2" should be set to the minimum value.
<p>"T1" Thermostat switch (Stop)                      The feature measures the internal oil temperature of the transformer. The normal operating value is to be set by the user according to the transformer manufacturers instructions. At a pre set temperature the stop circuit is triggered by a change over contact (T1).</p>	30 °C to 120 °C	The adjustment knob of the stop switch "T1" should be set to zero. The adjustment knob of the stop switch "T1" should be set to the minimum value.
<p><b>Thermometer</b>                      The device measures the internal temperature of the transformer, which shall be visualized outside the device through the protection window.                      The thermometer is equipped with a drag pointer.</p>	30 °C to 160 °C	The protection window is to be unscrewed so that the pointer shall be set to the minimum values.

## 2. Comem RIS2

### 2.3 Drawings

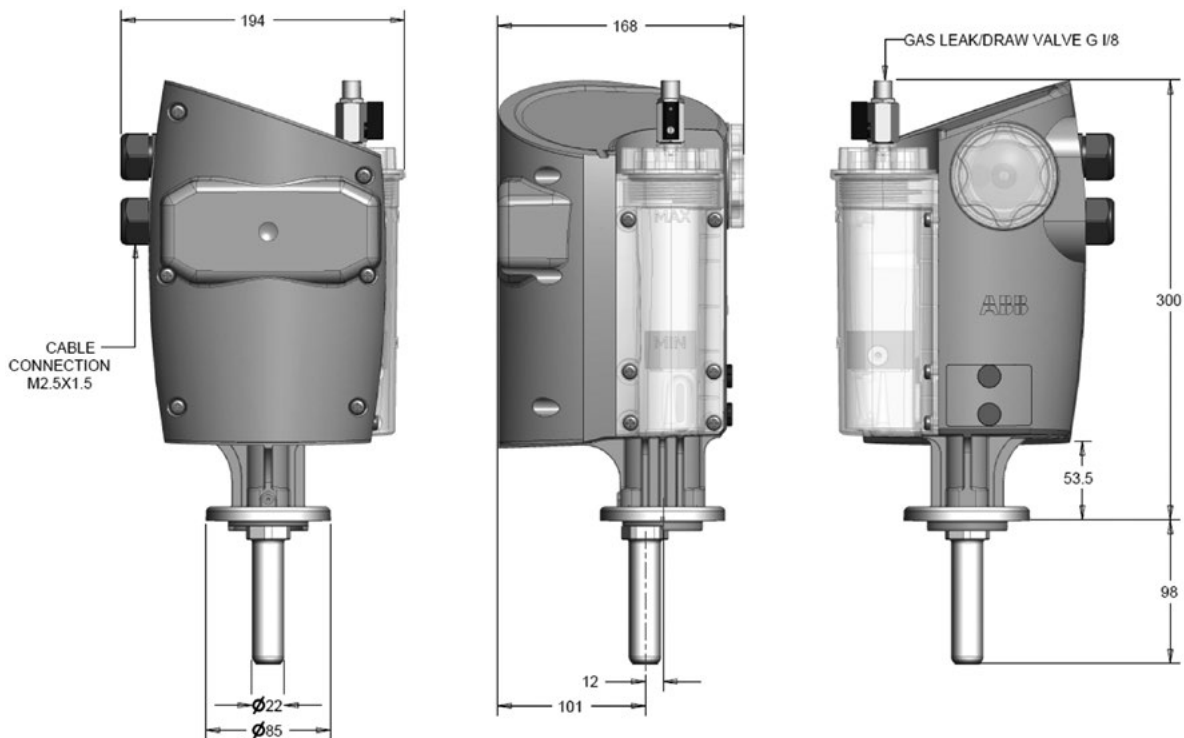

All dimensions in mm

### 2.4 General feature

General feature	
Degree of protection (EN 60529)	IP66
Salt-fog tight	1000 h
UV-Ray resistance (UNI-ISO 4892 / UNI-ISO 4582)	500 h
Measuring range	-40°C to +120°C
Environment temperature	-40°C to 55°C
Cable connection	M 25 x 1.5
Cable box (EN 50005 / EN 60947-7-1 / IEC 947-7-1)	According to standard
Wire section to be used on clamp box	Up to 2.5 mm <sup>2</sup>
Max. rated pressure	500 mbar
Electrical characteristics	Double insulation

## 2. Comem RIS2

### 2.5 Current

Current	ac						dc						
	Ohmic			Ohmic inductive ( $\cos\phi > 0,5$ )			Ohmic			Ohmic inductive ( $L/R < 40ms$ )			
Voltage	220	127	24										
Electric rating	Oil level	2A	2A	2A	2A	2A	2A	2A	2A	2A	2A	2A	2A
	Pressure switch	6A	6A	6A	2A	2A	2A	0,6A	0,6A	0,6A	0,6A	0,6A	0,6A
	Thermostat	16A	16A	16A	4A	4A	4A	0,6A	0,6A	0,6A	0,2A	0,3A	1,8A

### 2.6 Wiring diagram

#### 2.6.1 Wiring diagram by EN 50005 Standard

- Temp. STOP "T1" (terminals 44-41-42)
- Temp. ALARM "T2" (terminals 34-31-32)
- Pressure (terminals 24-21-22)
- Oil level (terminals 14-11-12)
- Options (flagged if present):
  - 4-20 mA
  - 2nd pressure switch
  - PT100

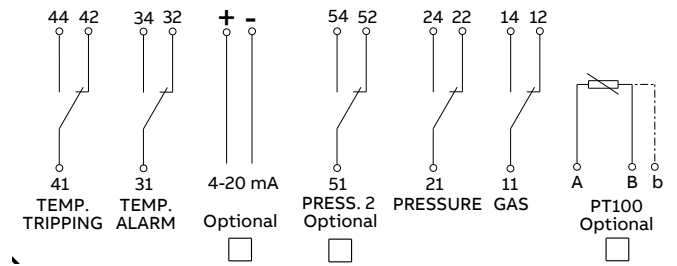

#### 2.6.2 Special wiring diagram "6 switches"

– upon request

- Temp. STOP "T1" (terminals 44-41-42)
- Temp. ALARM "T2" (terminals 34-31-32)
- Pressure 1 (terminals 24-21-22)
- Pressure 2 (terminals 54-51-52)
- Oil level 1 (terminals 14-11-12)
- Oil level 2 (terminals 64-61-62)
- Option (flagged if present):
  - 4-20 mA

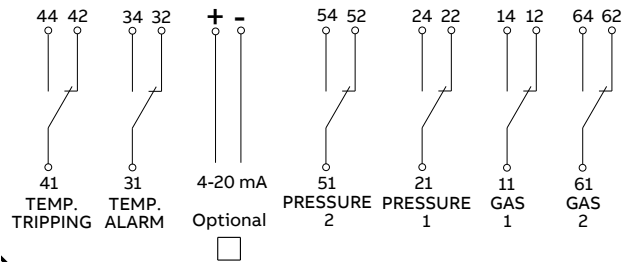

## 3. Installation

### 3.1 Mounting instruction

#### Application to a transformer tank

- $\varnothing 60 \text{ mm} \pm 1 \text{ mm}$  diam. hole on the tank
- Flat gasket (provided with the unit)
- Stainless steel fixing brackets (4 pcs packed)
- Stainless steel flat washers according to UNI 6592  $\varnothing 8,4 \text{ mm}$  (4 pcs packed)
- Stainless steel spring washers according to UNI 1751  $\varnothing 8,4 \text{ mm}$  (4 pcs packed)
- Stainless steel M8 nuts according to UNI 5588 (4 pcs packed).

Tighten the nuts in position 1,2,3,4 with torque nut 3 Nm to 4 Nm in a cross pattern; repeat the operation following the same sequence until the suggested value (6 Nm to 8 Nm) is reached.

Due to the deformation of the cover during lifting of the transformer, an oil leak could be possible. It is suggested to use covers of suitable thickness (min. 6-8 mm).

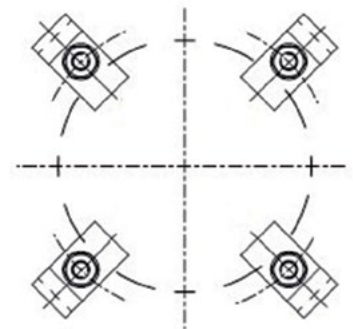
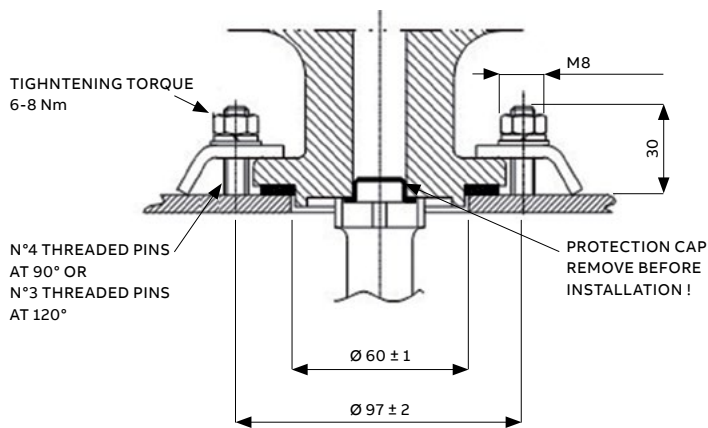

Normal working conditions

Anomaly conditions (Comem RIS2 intervention)

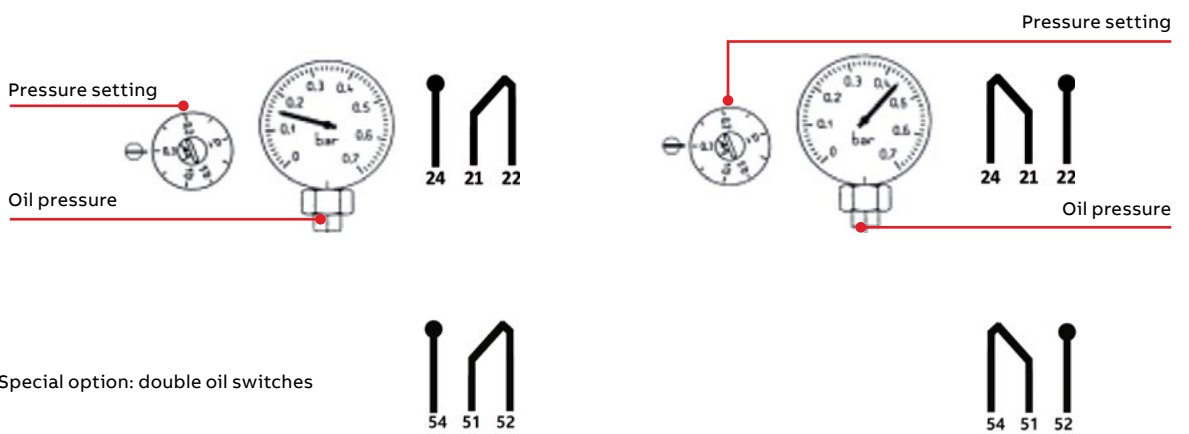
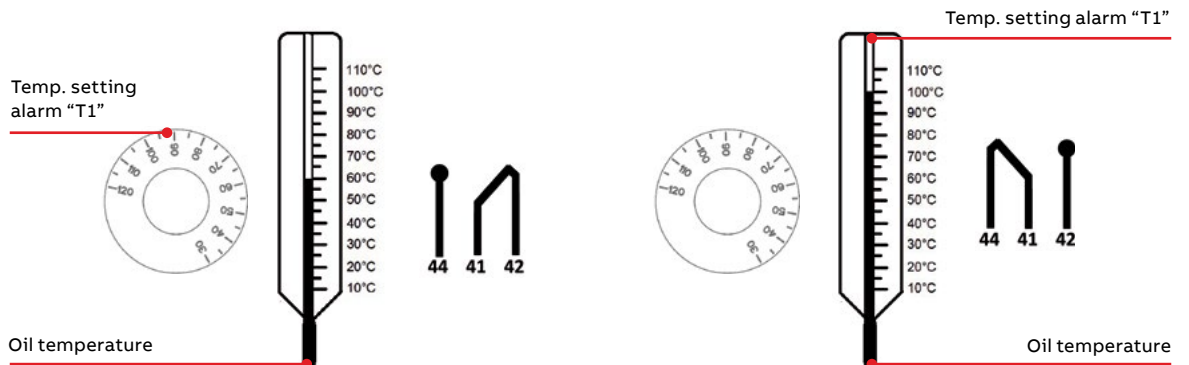
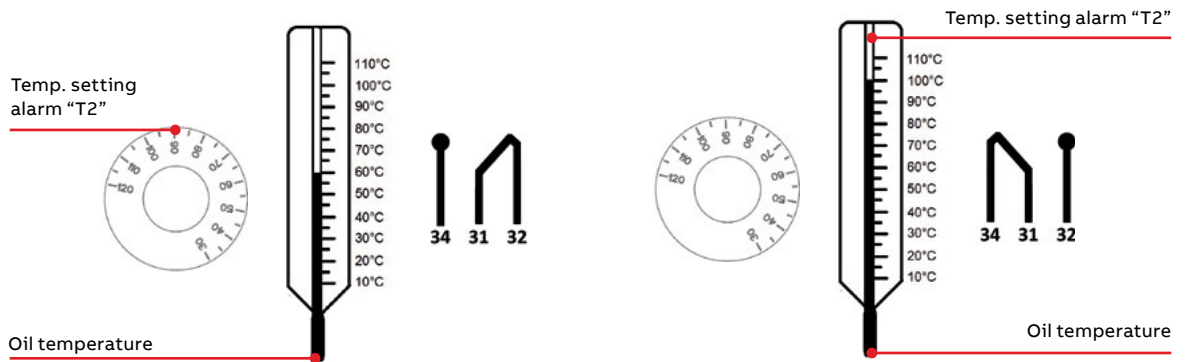
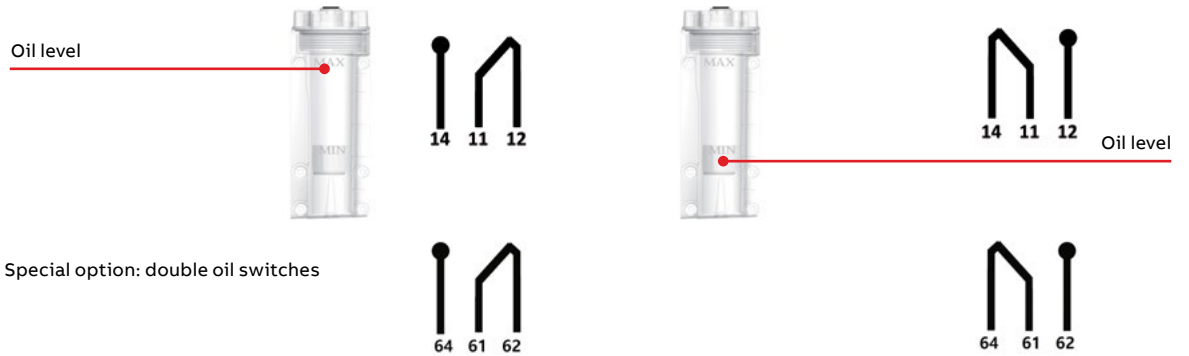

## 3. Installation

### 3.2 Installations and operating instructions

- Before installing the device remove the protective cap from the oil down flow hole.
- Ensure the bearing surface is smooth and flat.
- A four stud fixing is recommended.
- Protect Comem RIS2 device from any subsequent paint operation.
- Only install Comem RIS2 after the transformer drying operation.
- Switch off the supply voltage prior to working on Comem RIS2
- Operation and maintenance of Comem RIS2 should only be carried out by skilled personnel.
- ABB disclaim all responsibility for incorrect installation or improper use.
- On receipt of the goods please check the attached test certificate.
- The Comem RIS2 is guaranteed against defective parts for 12 months.
- Do not use powerful solvents or benzene's for cleaning. A damp cloth should.
- Do not remove float from inside Comem RIS2



#### WARNING

- **DO NOT USE THE OIL FILTER ON THE COMEM RIS2 FOR GENERAL FILLING OF THE TRANSFORMER, ONLY FOR TOPPING UP THE DEVICE**
- **WHEN FILLING THE COMEM RIS2. WITH OIL MAKE SURE THE BLEED COCK IS OPEN AND FILL UNTIL FLOAT REACHES THE "MAX" POSITION.**
- **AFTER FILLING ENSURE THE BLEED COCK AND FILLER CAP ARE FULLY CLOSED. HAND TIGHTEN ONLY, NO TOOLS REQUIRED.**
- **AFTER SETTING THE THERMOMETER POINTER ENSURE THE PROTECTIVE WINDOW IS SECURED, HAND TIGHTEN ONLY.**
- **CHECK THE CABLE GLAND M25X1,5 IS SECURELY FITTED.**
- **THE EVENT OF A MAJOR OIL LEVEL VARIATION OR HIGH GAS EVOLVEMENT THE FLOAT WILL REACH "MIN" POSITION, TRIGGERING THE ALARM SWITCH, IT WILL THEN BE NECESSARY TO BLEED OFF GAS OR ADD OIL.**

### 3.3 Instructions for topping up the level on Comem RIS2

#### Foreword

The device is filled with oil exclusively by the transformer manufacturer at environment temperature. At the time of putting into service, ensure what Comem RIS2 device is completely filled with oil. For various reasons, the oil may be below the set level. If the transformer is warm, due to high environment temperature or to its own operation, the internal pressure may increase, causing a visible drop in the oil level in the chamber of the device.

- To solve this problem it is sufficient to remove the lead seal on the lever of the tap 1 (see diagram), partly unscrew cap 2, slightly turn the lever of tap 1, thus releasing pressure and causing the oil level to rise until the device is completely full. After operation, ensure that cap 2 is closed and clean off any oil I that may have leaked out of the device.
- When the transformer is cold, due to a long period of inactivity, and/or an outdoor temperature below that of the environment, a vacuum may form inside the transformer, with consequent fall of the oil level visible on the external chamber of the device. This problem may be solved by removing the lead seal on the cap 2, unscrewing the cap 6 and topping up the oil level slowly with the aid of a funnel until the device is completely full, taking care not to let it overflow. Close the device with the cap 6.



### 3. Installation



CAUTION

IT IS RECOMENDED TO CLOSE THE CUP 6 WITHOUT TOOLS OR SPANNER. AT LEAST, IT IS POSSIBLE TO USE A DEDICATED TOOL: (SEE PICTURE 2)

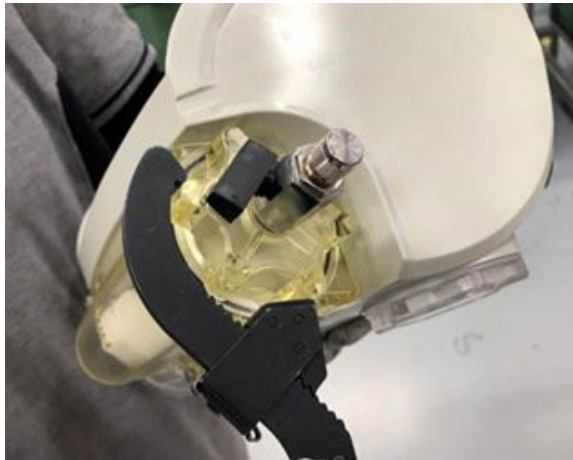

Picture 2

Once the oil level in the device has been topped up, the transformer may be started. If there is no oil available for topping up, ABB supplies a set of accessories with the pump which can create a vacuum in the device, thus restoring the oil level.

**Instructions**

The operations are performed as follows:

- A) Remove the cap “2”, screw the valve “3” and its nipple onto the tap “1”.
- B) Remove the cap “4”, fit the pump “5” by means of the threaded coupling provided and turn the lever to OFF position.
- C) The pump is already set to create a vacuum.
- D) To restore the oil level inside the R.I.S. device, open the lever of the tap “1” and suck with the pump “5”. After this operation, close the lever of the tap “1”.
- E) Release air from the pump, turning the lever to ON position.

If the oil level reached is not sufficient, repeat operations “D” and “E”.

Once the operations are complete, remove the components “5” and “3” and close the device with the cap “2”.

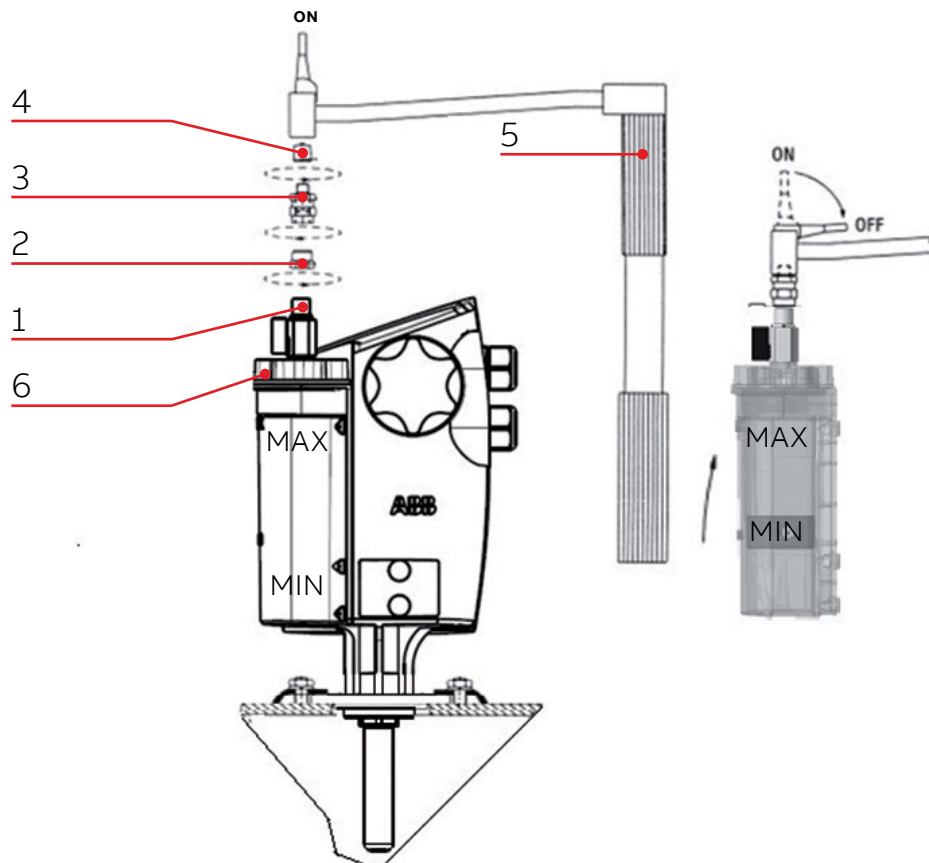

# 3. Installation

## 3.4 Drawings

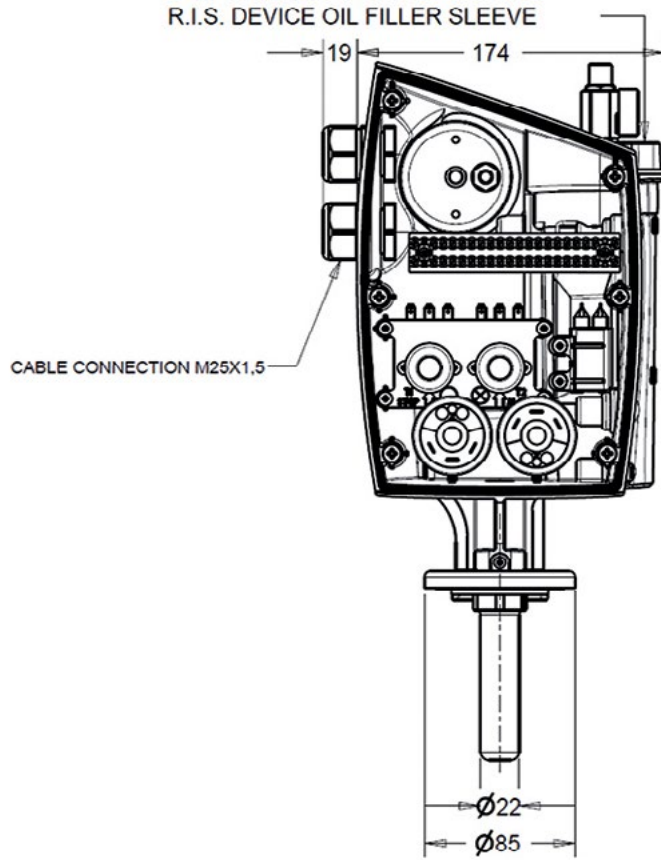

FOR CHECKING TEST (ON REQUEST)

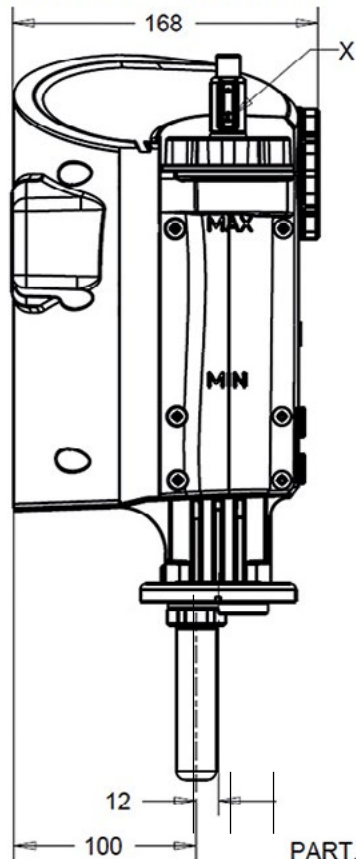

GAS BLEEDING/REMOVING VALVE G 1/8

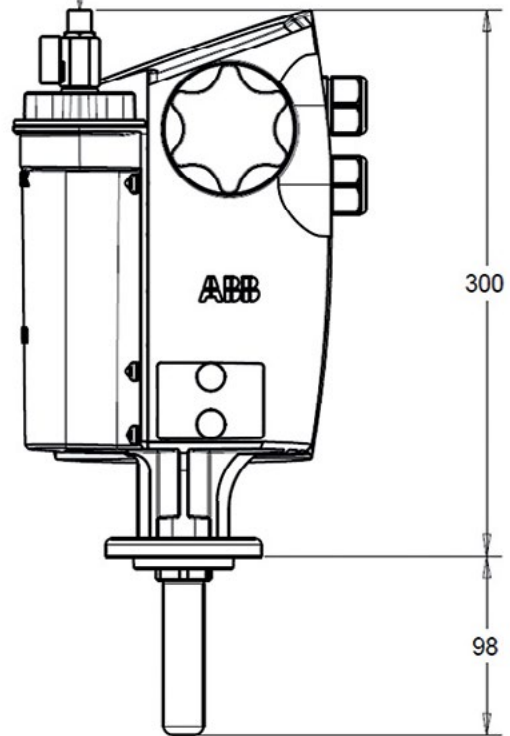

All dimensions in mm

## 4. Test

Comem RIS2 has fully passed the type tests prescribed by both European Standard EN 50216-3 and by ABB internal technical standards, which are listed as follows:

### Type tests

- Pressure overload: 2.5 bar - 2 minutes - with oil at 115 °C
- Operation at extreme temperatures: at -40 °C and 120 °
- Classification of the IP 66 protection rating: EN 60529
- Classification of ambient conditions: 4K2, 4Z2, 4B1, 4C2, 4S3, according to EN 60721-3-4
- Mechanical vibrations 4M4 (shock 250 m/sec<sup>2</sup>. Time spectrum "I": 11 ms), according to EN 60721-3-4
- Gas or oil volume for contact switching at ambient temperature and at the average working temperature of the transformer: max. 150 cm<sup>3</sup>
- Contact response time: < 0.5 seconds
- Allowed max. magnetic field value: 25 mT (no intervention of Comem RIS2 According to EN 50216-3
- Tightness test - 1000 hours in saline saturated atmosphere UNI-ISO 9227-93 (NSS)
- Tightness test against UV ageing according to UNI ISO 4892.

### Routine tests

Before shipment each piece is also subjected to the following routine tests:

- Tightness test: 30 minutes - 1 bar - with oil at 90 °C
- Operation of thermostats
- Pressure switch operation
- Oil level switch operation

### Options on request

- Pneumatic pump set / oil re-fill in altitude. Code: 1ZBG000053-SPAR.

### Supply conditions

Comem RIS2 is supplied in a single sturdy carton (dimensions: 400 mm x 200 mm x 160 mm, weight: 2.2 kg) and complete with the following accessories:

- Instruction booklet for installation and use
- Fixing kit
- Test report.

